

6

5

4

3

2

1

D

C

B

A

REVISION RECORD			
LTR	ECO NO:	APPROVED:	DATE:

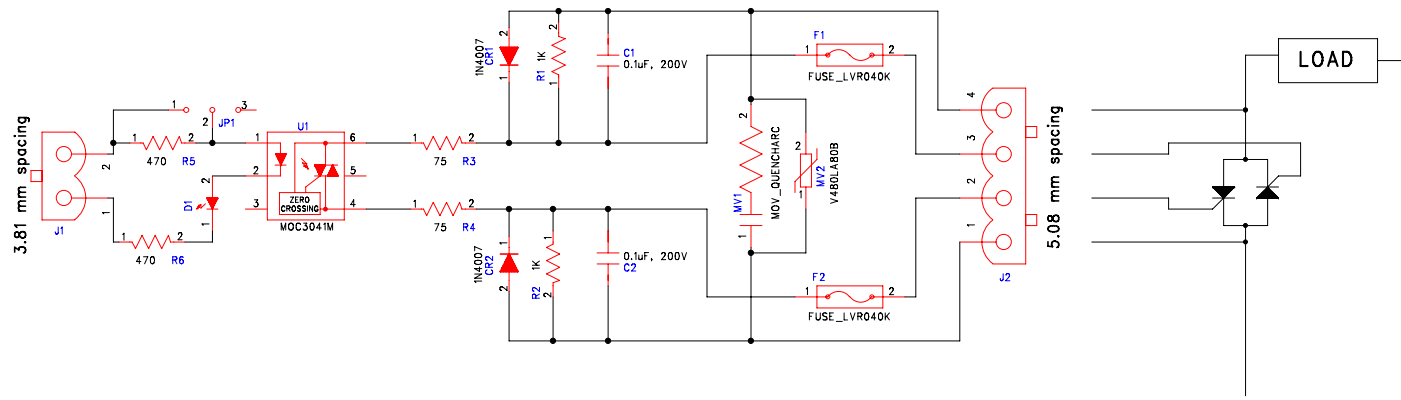

- MH1
- MH2
- MH3
- MH4

DRAWN:	DATED:
wrt	11/14/07
CHECKED:	DATED:
QUALITY CONTROL:	DATED:
RELEASED:	DATED:

COMPANY: Integrated Time Systems, Inc. San Jose, CA 95129			
TITLE: SCR Firing Circuit			
CODE:	SIZE: B	DRAWING NO: 9990535	REV: B
SCALE:		SHEET: 1 OF 1	

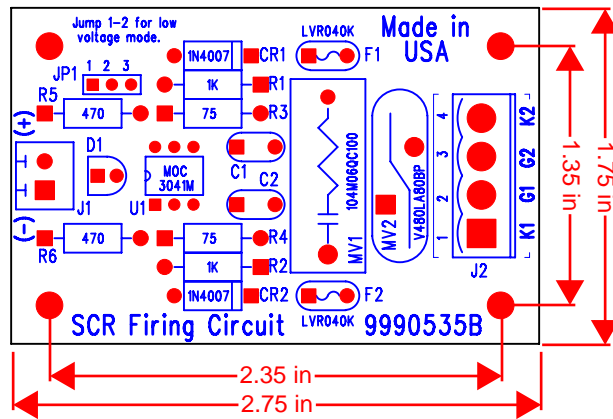

Integrated Time Systems, Inc.
 Part Number 9990535B
 November 14, 2007
 LAYER 1, COMPONENT SIDE